

# Solutions to JEE(Main)-2019

Test Date: 9<sup>th</sup> April 2019 (First Shift)

## PHYSICS, CHEMISTRY & MATHEMATICS

Paper - 1

Time Allotted: 3 Hours

Maximum Marks: 360

- Please read the instructions carefully. You are allotted 5 minutes specifically for this purpose.

### **Important Instructions:**

1. The test is of **3 hours** duration.
2. This **Test Paper** consists of **90** questions. The maximum marks are **360**.
3. There are **three** parts in the question paper A, B, C consisting of **Physics, Chemistry** and **Mathematics** having 30 questions in each part of equal weightage. Each question is allotted **4 (four)** marks for correct response.
4. Out of the four options given for each question, only one option is the correct answer.
5. For each incorrect response 1 mark i.e.  $\frac{1}{4}$  (**one-fourth**) marks of the total marks allotted to the question will be deducted from the total score. No deduction from the total score, however, will be made if no response is indicated for an item in the Answer Box.
6. *Candidates will be awarded marks as stated above in **instruction No.3** for correct response of each question. One mark will be deducted for indicating incorrect response of each question. No deduction from the total score will be made if no response is indicated for an item in the answer box.*
7. There is only one correct response for each question. Marked up more than one response in any question will be treated as wrong response and marked up for wrong response will be deducted accordingly as per **instruction 6** above.

## PART –A (PHYSICS)

1. In the density measurement of a cube, the mass and edge length are measured as  $(10.00 \pm 0.10)$  kg and  $(0.10 \pm 0.01)$  m, respectively. The error in the measurement of density is:  
 (A)  $0.10 \text{ kg/m}^3$  (B)  $0.31 \text{ kg/m}^3$   
 (C)  $0.07 \text{ kg/m}^3$  (D)  $0.01 \text{ kg/m}^3$

2. The total number of turns and cross-section area in solenoid is fixed. However, its length  $L$  is varied by adjusting the separation between windings. The inductance of solenoid will be proportional to:  
 (A)  $1/L$  (B)  $L$   
 (C)  $1/L^2$  (D)  $L^2$

3. The figure shows a Young's double slit experimental setup. It is observed that when a thin transparent sheet of thickness  $t$  and refractive index  $\mu$  is put in front of one of the slits, the central maximum gets shifted by a distance equal to  $n$  fringe widths. If the wavelength of light used is  $\lambda$ ,  $t$  will be:

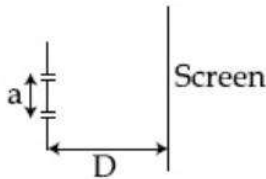

- (A)  $\frac{2nD\lambda}{a(\mu-1)}$  (B)  $\frac{nD\lambda}{a(\mu-1)}$   
 (C)  $\frac{2D\lambda}{a(\mu-1)}$  (D)  $\frac{D\lambda}{a(\mu-1)}$

4. A system of three charges are placed as shown in the figure:

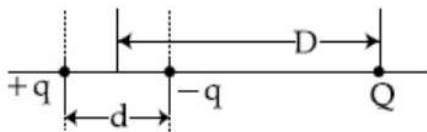

If  $D \gg d$ , the potential energy of the system is best given by:

- (A)  $\frac{1}{4\pi\epsilon_0} \left[ -\frac{q^2}{d} - \frac{qQd}{D^2} \right]$  (B)  $\frac{1}{4\pi\epsilon_0} \left[ -\frac{q^2}{d} - \frac{qQd}{2D^2} \right]$   
 (C)  $\frac{1}{4\pi\epsilon_0} \left[ -\frac{q^2}{d} + \frac{2qQd}{D^2} \right]$  (D)  $\frac{1}{4\pi\epsilon_0} \left[ +\frac{q^2}{d} - \frac{qQd}{D^2} \right]$

5. A moving coil galvanometer has resistance  $50 \Omega$  and it indicates full deflection at  $4 \text{ mA}$  current. A voltmeter is made using this galvanometer and a  $5 \text{ k}\Omega$  resistance. The maximum voltage, that can be measured using this voltmeter, will be close to:  
 (A)  $15 \text{ V}$  (B)  $20 \text{ V}$   
 (C)  $10 \text{ V}$  (D)  $40 \text{ V}$

6. If 'M' is the mass of water that rises in a capillary tube of radius 'r', then mass of water which will rise in a capillary tube of radius '2r' is:
- (A) 4 M (B)  $\frac{M}{2}$   
 (C) M (D) 2 M
7. An NPN transistor is used in common emitter configuration as an amplifier with 1 k $\Omega$  load resistance. Signal voltage of 10 mV is applied across the base-emitter. This produces a 3 mA change in the collector current and 15  $\mu$ A change in the base current of the amplifier. The input resistance and voltage gain are:
- (A) 0.67 k $\Omega$ , 300 (B) 0.67 k $\Omega$ , 200  
 (C) 0.33 k $\Omega$ , 1.5 (D) 0.33 k $\Omega$ , 300
8. An HCl molecule has rotational, translational and vibrational motions. If the rms velocity of HCl molecules in its gaseous phase is  $\bar{v}$ , m is its mass and  $k_B$  is Boltzmann constant, then its temperature will be:
- (A)  $\frac{mv^{-2}}{3k_B}$  (B)  $\frac{mv^{-2}}{7k_B}$   
 (C)  $\frac{mv^{-2}}{5k_B}$  (D)  $\frac{mv^{-2}}{6k_B}$
9. The electric field of light wave is given as  $\vec{E} = 10^{-3} \cos\left(\frac{2\pi x}{5 \times 10^{-7}} - 2\pi \times 6 \times 10^{14} t\right) \hat{x} \frac{N}{C}$ . This light falls on a metal plate of work function 2eV. The stopping potential of the photoelectrons is:
- (A) 0.48 V (B) 2.48 V  
 (C) 0.72 V (D) 2.0 V
10. Following figure shows two processes A and B for a gas. If  $\Delta Q_A$  and  $\Delta Q_B$  are the amount of heat absorbed by the system in two cases, and  $\Delta U_A$  and  $\Delta U_B$  are changes in internal energies, respectively, then:

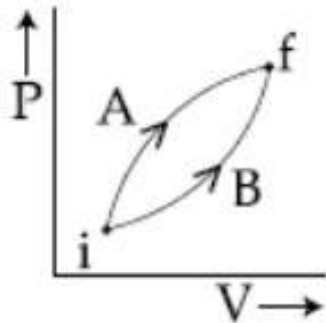

- (A)  $\Delta Q_A = \Delta Q_B$ ;  $\Delta U_A = \Delta U_B$  (B)  $\Delta Q_A > \Delta Q_B$ ;  $\Delta U_A = \Delta U_B$   
 (C)  $\Delta Q_A < \Delta Q_B$ ;  $\Delta U_A < \Delta U_B$  (D)  $\Delta Q_A > \Delta Q_B$ ;  $\Delta U_A > \Delta U_B$

11. A uniform cable of mass 'M' and length 'L' is placed on a horizontal surface such that its  $\left(\frac{1}{n}\right)^{\text{th}}$  part is hanging below the edge of the surface. To lift the hanging part of the cable upto the surface, the work done should be:

(A)  $nMgL$  (B)  $\frac{MgL}{2n^2}$   
 (C)  $\frac{2MgL}{n^2}$  (D)  $\frac{MgL}{n^2}$

12. The following bodies are made to roll up (without slipping) the same inclined plane from a horizontal place: (i) a ring of radius R, (ii) a solid cylinder of radius  $\frac{R}{2}$  and (iii) a solid sphere of radius  $\frac{R}{4}$ . If, in each case, the speed of the center of mass at bottom of the incline is same, the ratio of the maximum heights they climb is:

(A) 10 : 15 : 7 (B) 14 : 15 : 20  
 (C) 4 : 3 : 2 (D) 2 : 3 : 4

13. A signal  $A \cos \omega t$  is transmitted using  $v_0 \sin \omega_0 t$  as carrier wave. The correct amplitude modulated (AM) signal is:

(A)  $v_0 \sin[\omega_0 (1 + 0.01A \sin \omega t) t]$   
 (B)  $v_0 \sin \omega_0 t + \frac{A}{2} \sin(\omega_0 - \omega) t + \frac{A}{2} \sin(\omega_0 + \omega) t$   
 (C)  $v_0 \sin \omega_0 t + A \cos \omega t$   
 (D)  $(v_0 + A) \cos \omega t \sin \omega_0 t$

14. A concave mirror for face viewing has focal length of 0.4 m. The distance at which you hold the mirror from your face in order to see your image upright with a magnification of 5 is:

(A) 0.16 m (B) 1.60 m  
 (C) 0.24 m (D) 0.32 m

15. Determine the charge on the capacitor in the following circuit:

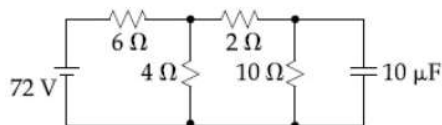

(A)  $200 \mu\text{C}$  (B)  $60 \mu\text{C}$   
 (C)  $10 \mu\text{C}$  (D)  $2 \mu\text{C}$

16. A rectangular coil (Dimension  $5 \text{ cm} \times 2 \text{ cm}$ ) with 100 turns, carrying a current of 3 A in the clock-wise direction, is kept centered at the origin and in the X-Z plane. A magnetic field of 1 T is applied along X-axis. If the coil is tilted through  $45^\circ$  about Z-axis, then the torque on the coil is:

(A) 0.42 Nm (B) 0.55 Nm  
 (C) 0.27 Nm (D) 0.38 Nm

17. A stationary horizontal disc is free to rotate about its axis. When a torque is applied on it, its kinetic energy as a function of  $\theta$ , where  $\theta$  is the angle by which it has rotated, is given as  $k\theta^2$ . If its moment of inertia is  $I$  then the angular acceleration of the disc is:
- (A)  $\frac{k}{I}\theta$  (B)  $\frac{k}{2I}\theta$   
 (C)  $\frac{k}{4I}\theta$  (D)  $\frac{2k}{I}\theta$
18. A simple pendulum oscillating in air has period  $T$ . The bob of the pendulum is completely immersed in a non-viscous liquid. The density of the liquid is  $\frac{1}{16}$ th of the material of the bob. If the bob is inside liquid all the time, its period of oscillation in this liquid is:
- (A)  $2T\sqrt{\frac{1}{10}}$  (B)  $2T\sqrt{\frac{1}{14}}$   
 (C)  $4T\sqrt{\frac{1}{15}}$  (D)  $4T\sqrt{\frac{1}{14}}$
19. For a given gas at 1 atm pressure, rms speed of the molecules is 200 m/s at 127°C. At 2 atm pressure and at 227°C, the rms speed of the molecules will be:
- (A) 80 m/s (B)  $80\sqrt{5}$  m/s  
 (C) 100 m/s (D)  $100\sqrt{5}$  m/s
20. The magnetic field of a plane electromagnetic wave is given by:  
 $\vec{B} = B_0 \hat{i} [\cos(kz - \omega t)] + B_1 \hat{j} \cos(kz - \omega t)$  where  $B_0 = 3 \times 10^{-5} \text{T}$  and  $B_1 = 2 \times 10^{-6} \text{T}$ . The rms value of the force experienced by a stationary charge  $Q = 10^{-4} \text{C}$  at  $z = 0$  is closet to:
- (A) 0.9 N (B) 0.6 N  
 (C) 0.1 N (D)  $3 \times 10^{-2} \text{N}$
21. The stream of a river is flowing with a speed of 2 km/h. A swimmer can swim at a speed of 4 km/h. What should be the direction of the swimmer with respect to the flow of the river to cross the river straight?
- (A) 60° (B) 90°  
 (C) 120° (D) 150°
22. A rigid square loop of side 'a' and carrying current  $I_2$  is laying on a horizontal surface near a long current  $I_1$  wire in the same plane as shown in figure. The net force on the loop due to the wire will be:

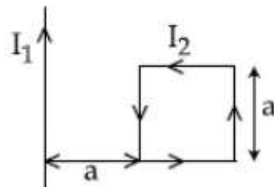

- (A) Repulsive and equal to  $\frac{\mu_0 I_1 I_2}{2\pi}$  (B) Attractive and equal to  $\frac{\mu_0 I_1 I_2}{3\pi}$   
 (C) Zero (D) Repulsive and equal to  $\frac{\mu_0 I_1 I_2}{4\pi}$

23. Taking the wavelength of first Balmer line in hydrogen spectrum ( $n = 3$  to  $n = 2$ ) as 660 nm, the wavelength of the 2<sup>nd</sup> Balmer line ( $n = 4$  to  $n = 2$ ) will be  
 (A) 889.2 nm (B) 642.7 nm  
 (C) 448.9 nm (D) 388.9 nm
24. A solid sphere of mass 'M' and radius 'a' is surrounded by a uniform concentric spherical shell of thickness 2a and mass 2M. The gravitational field at distance '3a' from the centre will be:  
 (A)  $\frac{2GM}{3a^2}$  (B)  $\frac{2GM}{9a^2}$   
 (C)  $\frac{GM}{9a^2}$  (D)  $\frac{GM}{3a^2}$
25. A string is clamped at both the ends and it is vibrating in its 4<sup>th</sup> harmonic. The equation of the stationary wave is  $Y = 0.3 \sin(0.157x) \cos(200\pi t)$ . The length of the string is: (all quantities are in SI units)  
 (A) 80 m (B) 60 m  
 (C) 40 m (D) 20 m
26. A ball is thrown vertically up (taken as +z-axis) from the ground. The correct momentum-height (p-h) diagram is:

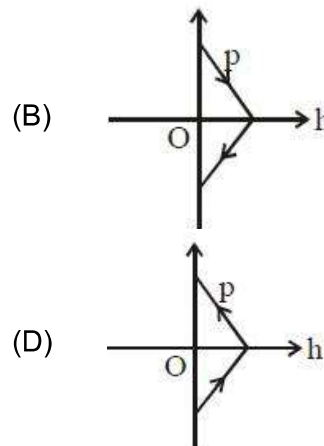
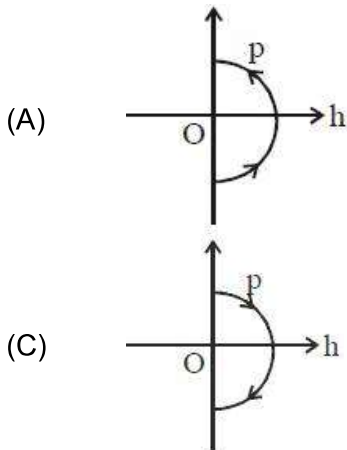

27. A capacitor with capacitance 5  $\mu\text{F}$  is charged to 5  $\mu\text{C}$ . If the plates are pulled apart to reduce the capacitance to 2  $\mu\text{F}$ , how much work is done?  
 (A)  $3.75 \times 10^{-6}$  J (B)  $2.55 \times 10^{-6}$  J  
 (C)  $6.25 \times 10^{-6}$  J (D)  $2.16 \times 10^{-6}$  J
28. A body of mass 2 kg makes an elastic collision with a second body at rest and continues to move in the original direction but with one fourth of its original speed. What is the mass of the second body?  
 (A) 1.5 kg (B) 1.2 kg  
 (C) 1.8 kg (D) 1.0 kg

29. The pressure wave,  $P = 0.01 \sin[1000t - 3x] \text{NM}^{-2}$ , corresponds to the sound produced by a vibrating blade on a day when atmospheric temperature is  $0^\circ\text{C}$ . On some other day when temperature is  $T$ , the speed of sound produced by the same blade and at the same frequency is found to be  $336 \text{ms}^{-1}$ . Approximate value of  $T$  is:

(A)  $12^\circ\text{C}$  (B)  $11^\circ\text{C}$   
(C)  $15^\circ\text{C}$  (D)  $4^\circ\text{C}$

30. A wire of resistance  $R$  is bent to form a square ABCD as shown in the figure. The effective resistance between E and C is: (E is mid-point of arm CD)

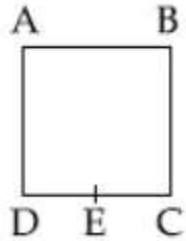

(A)  $\frac{1}{16}R$  (B)  $\frac{7}{64}R$   
(C)  $\frac{3}{4}R$  (D)  $R$

## PART –B (CHEMISTRY)

31. Magnesium powder burns in air to give:  
 (A) MgO and Mg(NO<sub>3</sub>)<sub>2</sub> (B) MgO and Mg<sub>3</sub>N<sub>2</sub>  
 (C) MgO only (D) Mg(NO<sub>3</sub>)<sub>2</sub> and Mg<sub>3</sub>N<sub>2</sub>
32. The number of water molecule(s) not coordinated to copper ion directly in CuSO<sub>4</sub>·5H<sub>2</sub>O, is:  
 (A) 1 (B) 3  
 (C) 2 (D) 4

33. The one that will show optical activity is: (en = ethane-1, 2-diamine)

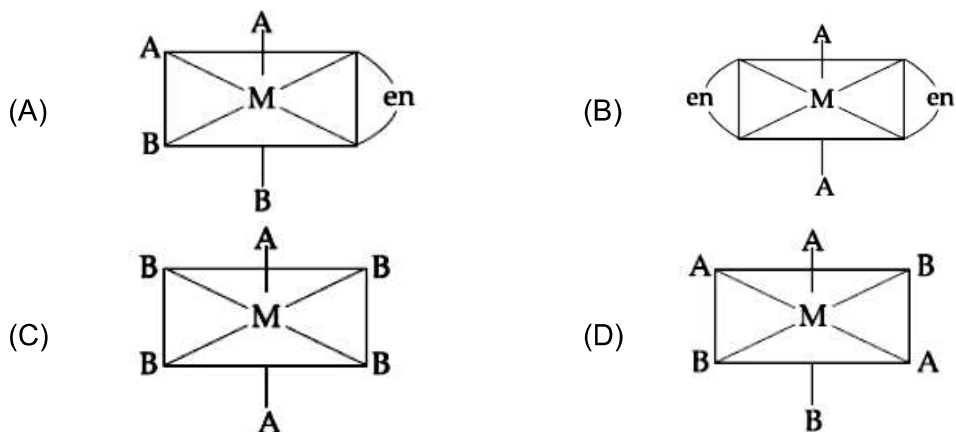

34. Consider the van der Waals constants, a and b, for the following gases.

Gas	Ar	Ne	Kr	Xe
a/(atm dm <sup>6</sup> mol <sup>-2</sup> )	1.3	0.2	5.1	4.1
b/(10 <sup>-2</sup> dm <sup>3</sup> mol <sup>-1</sup> )	3.2	1.7	1.0	5.0

Which gas is expected to have the highest critical temperature?

- (A) Ar (B) Xe  
 (C) Kr (D) Ne
35. Among the following, the molecule expected to be stabilized by anion formation is:  
 (A) F<sub>2</sub> (B) C<sub>2</sub>  
 (C) O<sub>2</sub> (D) NO

36. Liquid 'M' and liquid 'N' form an ideal solution. The vapour pressures of pure liquids 'M' and 'N' are 450 and 700 mm Hg, respectively at the same temperature. Then correct statement is:

(x<sub>M</sub> = mole fraction of 'M' in solution; x<sub>N</sub> = mole fraction of 'N' in solution;  
 y<sub>M</sub> = mole fraction of 'M' in vapour phase; y<sub>N</sub> = mole fraction of 'N' in vapour phase)

- (A)  $\frac{x_M}{x_N} > \frac{y_M}{y_N}$  (B)  $\frac{x_M}{x_N} = \frac{y_M}{y_N}$   
 (C)  $(x_M - y_M) < (x_N - y_N)$  (D)  $\frac{x_M}{x_N} < \frac{y_M}{y_N}$



37. Among the following the set of parameters that represents path functions, is:  
 (a)  $q + w$  (b)  $q$   
 (c)  $w$  (d)  $H - TS$   
 (A) (b) and (c) (B) (b), (c) and (d)  
 (C) (a), (b) and (c) (D) (a) and (d)
38. The degenerate orbitals of  $[\text{Cr}(\text{H}_2\text{O})_6]^{3+}$  are:  
 (A)  $d_{xz}$  and  $d_{yz}$  (B)  $d_{x^2-y^2}$  and  $d_{xy}$   
 (C)  $d_{yz}$  and  $d_{z^2}$  (D)  $d_{z^2}$  and  $d_{xz}$
39. The aerosol is a kind of colloid in which:  
 (A) solid is dispersed in gas (B) gas is dispersed in solid  
 (C) liquid is dispersed in water (D) gas is dispersed in liquid
40. The given plots represent the variation of the concentration of a reactant R with time for two different reactions (i) and (ii). The respective orders of the reactions are:

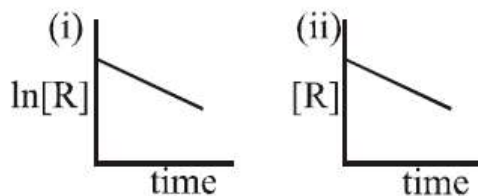

- (A) 1, 1 (B) 0, 2  
 (C) 0, 1 (D) 1, 0
41. The major product of the following reaction is:

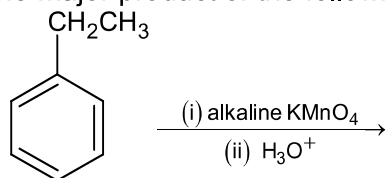

- (A) (B)
- (C) (D)

42. The organic compound that gives following qualitative analysis is:

	<b>Test</b>	<b>Inference</b>
(a)	Dil. HCl	Insoluble
(b)	NaOH solution	Soluble
(c)	$\text{Br}_2/\text{water}$	Decolourization

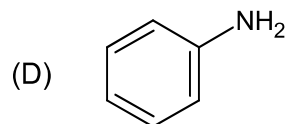
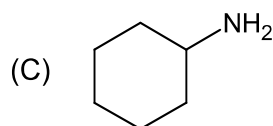
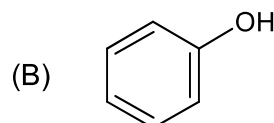
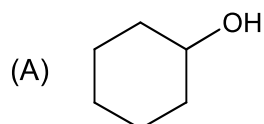

43. Aniline dissolved in dilute HCl is reacted with sodium nitrite at 0°C. This solution was added dropwise to a solution containing equimolar mixture of aniline and phenol in dil. HCl. The structure of the major product is:

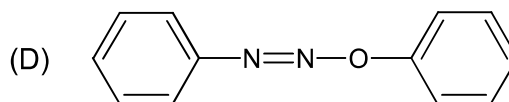
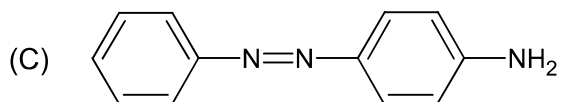
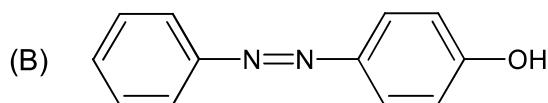
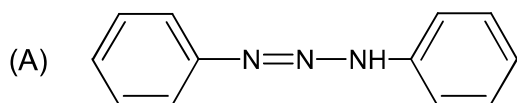

44. Excessive release of CO<sub>2</sub> into the atmosphere results in:  
(A) formation of smog (B) depletion of ozone  
(C) global warming (D) polar vortex
45. The ore that contains the metal in the form of fluoride is:  
(A) saphalerite (B) malachite  
(C) magnetite (D) cryolite
46. The correct IUPAC name of the following compound is

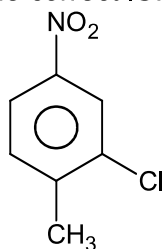

- (A) 5-chloro-4-methyl-1-nitrobenzene (B) 2-methyl-5-nitro-1-chlorobenzene  
(C) 3-chloro-4-methyl-1-nitrobenzene (D) 2-chloro-1-methyl-4-nitrobenzene
47. The major product of the following reaction is :  
$$\text{CH}_3\text{CH}=\text{CHCO}_2\text{CH}_3 \xrightarrow{\text{LiAlH}_4}$$
  
(A) CH<sub>3</sub>CH<sub>2</sub>CH<sub>2</sub>CHO (B) CH<sub>3</sub>CH = CHCH<sub>2</sub>OH  
(C) CH<sub>3</sub>CH<sub>2</sub>CH<sub>2</sub>CO<sub>2</sub>CH<sub>3</sub> (D) CH<sub>3</sub>CH<sub>2</sub>CH<sub>2</sub>CH<sub>2</sub>OH
48. The element having greatest difference between its first and second ionization energies, is  
(A) Ca (B) K  
(C) Ba (D) Sc

49. For a reaction,  $N_2(g) + 3H_2(g) \rightarrow 2NH_3(g)$ ; identify dihydrogen ( $H_2$ ) as a limiting reagent in the following reaction mixtures.

- (A) 14g of  $N_2$  + 4g of  $H_2$  (B) 28g of  $N_2$  + 6g of  $H_2$   
 (C) 56g of  $N_2$  + 10g of  $H_2$  (D) 35g of  $N_2$  + 8g of  $H_2$

50. The major product of the following reaction is :

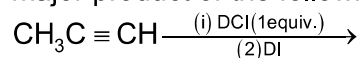

- (A)  $CH_3CD(I)CHD(Cl)$  (B)  $CH_3C(I)(Cl)CHD_2$   
 (C)  $CH_3CD_2CH(Cl)(I)$  (D)  $CH_3CD(Cl)CHD(I)$

51. The osmotic pressure of a dilute solution of an ionic compound XY in water is four times that of a solution of 0.01 M  $BaCl_2$  in water. Assuming complete dissociation of the given ionic compounds in water, the concentration of XY (in mol  $L^{-1}$ ) in solution is

- (A)  $4 \times 10^{-4}$  (B)  $6 \times 10^{-2}$   
 (C)  $16 \times 10^{-4}$  (D)  $4 \times 10^{-2}$

52. For any given series of spectral lines of atomic hydrogen, let  $\Delta\bar{\nu} = \Delta\bar{\nu}_{max} - \Delta\bar{\nu}_{min}$  be the difference in maximum and minimum frequencies in  $cm^{-1}$ . the ration  $\Delta\bar{\nu}_{Lyman} / \Delta\bar{\nu}_{Balmer}$  is

- (A) 5 : 4 (B) 4 : 1  
 (C) 9 : 4 (D) 27 : 5

53. The major product of the following reaction is:

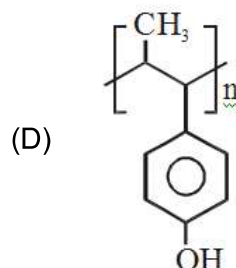
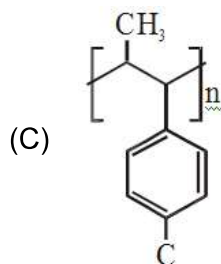
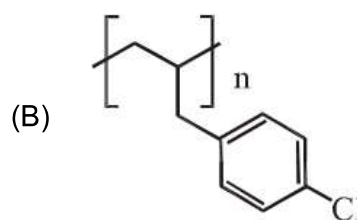
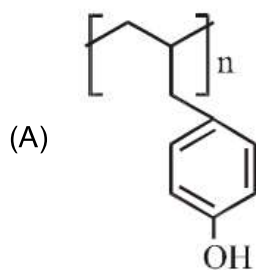
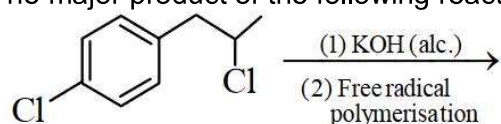

54. The increasing order of reactivity of the following compounds towards aromatic electrophilic substitution reaction is

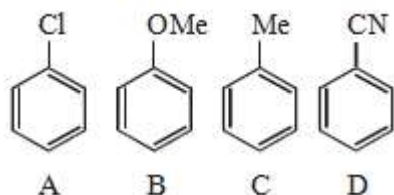

- (A)  $D < B < A < C$  (B)  $A < B < C < D$   
 (C)  $D < A < C < B$  (D)  $B < C < A < D$

55.  $C_{60}$ , an allotrope of carbon contains:

- (A) 20 hexagons and 12 pentagons. (B) 12 hexagons and 20 pentagons.  
 (C) 18 hexagons and 14 pentagons. (D) 16 hexagons and 16 pentagons

56. The correct order of the oxidation states of nitrogen in NO,  $N_2O$ ,  $NO_2$  and  $N_2O_3$  is:

- (A)  $N_2O < N_2O_3 < NO < NO_2$  (B)  $NO_2 < NO < N_2O_3 < N_2O$   
 (C)  $NO_2 < N_2O_3 < NO < N_2O$  (D)  $N_2O < NO < N_2O_3 < NO_2$

57. The standard Gibbs energy for the given cell reaction in  $\text{kJ mol}^{-1}$  at 298 K is:

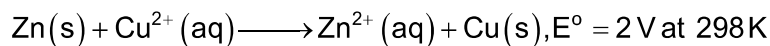

[Faraday's constant  $F = 96500 \text{ C mol}^{-1}$ ]

- (A) -192 (B) 384  
 (C) -384 (D) 192

58. The major product of the following reaction is:

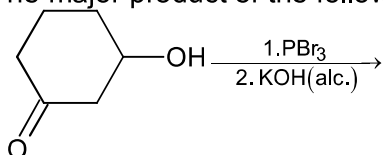

- (A) (B)   
 (C) (D)

59. Which of the following statements is not true about sucrose?

- (A) The glycosidic linkage is present between  $C_1$  of  $\alpha$ -glucose and  $C_1$  of  $\beta$ -fructose  
 (B) It is a non-reducing sugar  
 (C) It is also named as invert sugar  
 (D) On hydrolysis it produces glucose and fructose

60. Match the catalysis(Column – I) with products (Column-II)

<b>Column-I</b> <b>Catalyst</b>	<b>Column-II</b> <b>Product</b>
(a) $V_2O_5$	(i) Polyethylene
(b) $TiCl_4/Al(Me)_3$	(ii) Ethanal
(c) $PdCl_2$	(iii) $H_2SO_4$
(d) Iron oxide	(iv) $NH_3$
(A) (a)-(iii); (b)-(iv); (c)-(i); (d)-(ii)	(B) (a)-(iv); (b)-(iii); (c)-(ii); (d)-(i)
(C) (a)-(ii); (b)-(iii); (c)-(i); (d)-(iv)	(D) (a)-(iii); (b)-(i); (c)-(ii); (d)-(iv)

## **PART-C (MATHEMATICS)**

61. If the function  $f: \mathbb{R} - \{1, -1\} \rightarrow A$  defined by  $f(x) = \frac{x^2}{1-x^2}$ , is surjective, then A is equal to:  
(A)  $\mathbb{R} - [-1, 0)$  (B)  $\mathbb{R} - (-1, 0)$   
(C)  $\mathbb{R} - \{-1\}$  (D)  $[0, \infty]$
62. Let  $p, q \in \mathbb{R}$ . if  $2 - \sqrt{3}$  is a root of the quadratic equation,  $x^2 + px + q = 0$ , then:  
(A)  $q^2 + 4p + 14 = 0$  (B)  $p^2 - 4q + 12 = 0$   
(C)  $p^2 - 4q - 12 = 0$  (D)  $q^2 - 4p - 16 = 0$
63. Let  $\vec{\alpha} = 3\hat{i} + \hat{j}$  and  $\vec{\beta} = 2\hat{i} - \hat{j} + 3\hat{k}$ . If  $\vec{\beta} = \vec{\beta}_1 - \vec{\beta}_2$ , where  $\vec{\beta}_1$  is parallel to  $\vec{\alpha}$  and  $\vec{\beta}_2$  is perpendicular to  $\vec{\alpha}$ , then  $\vec{\beta}_1 \times \vec{\beta}_2$  is equal to:  
(A)  $\frac{1}{2}(-3\hat{i} + 9\hat{j} + 5\hat{k})$  (B)  $\frac{1}{2}(3\hat{i} - 9\hat{j} + 5\hat{k})$   
(C)  $-3\hat{i} + 9\hat{j} + 5\hat{k}$  (D)  $3\hat{i} - 9\hat{j} - 5\hat{k}$
64. The integral  $\int \sec^{2/3} x \operatorname{cosec}^{4/3} x \, dx$  is equal to: (Here C is a constant of integration)  
(A)  $3 \tan^{-1/3} x + C$  (B)  $-\frac{3}{4} \tan^{-4/3} x + C$   
(C)  $-3 \cot^{-1/3} x + C$  (D)  $-3 \tan^{-1/3} x + C$
65. A plane passing through the points  $(0, -1, 0)$  and  $(0, 0, 1)$  and making an angle  $\frac{\pi}{4}$  with plane  $y - z + 5 = 0$ , also passes through the point:  
(A)  $(\sqrt{2}, 1, 4)$  (B)  $(-\sqrt{2}, -1, -4)$   
(C)  $(-\sqrt{2}, 1, -4)$  (D)  $(\sqrt{2}, -1, 4)$
66. If the tangent to the curve,  $y = x^3 + ax - b$  at the point  $(1, -5)$  is perpendicular to the line,  $-x + y + 4 = 0$ , then which one of the following, points lies on the curve?  
(A)  $(2, -2)$  (B)  $(-2, 2)$   
(C)  $(-2, 1)$  (D)  $(2, -1)$
67. If the standard deviation of the numbers  $-1, 0, 1, k$  is  $\sqrt{5}$  where  $k > 0$ , then k is equal to:  
(A)  $4\sqrt{\frac{5}{3}}$  (B)  $\sqrt{6}$   
(C)  $2\sqrt{6}$  (D)  $2\sqrt{\frac{10}{3}}$
68. Let  $f(x) = 15 - |x - 10|$ ;  $x \in \mathbb{R}$ . then the set of all values of x, at which the function,  $g(x) = f(f(x))$  is not differentiable, is:  
(A)  $\{5, 10, 15\}$  (B)  $\{10\}$   
(C)  $\{5, 10, 15, 20\}$  (D)  $\{10, 15\}$

69. If the fourth term in the Binomial expansion of  $\left(\frac{2}{x} + x^{\log_8 x}\right)^6$  ( $x > 0$ ) is  $20 \times 8^7$ , then a value of  $x$  is:  
 (A)  $8^3$  (B)  $8^{-2}$   
 (C)  $8$  (D)  $8^2$
70. If  $f(x)$  is a non-zero polynomial of degree four, having local extreme points at  $x = -1, 0, 1$ ; then the set  $S = \{x \in \mathbb{R}; f(x) = f(0)\}$  contains exactly:  
 (A) four irrational numbers (B) four rational numbers  
 (C) two irrational and one rational number (D) two irrational and two rational numbers
71. For any two statements  $p$  and  $q$ , the negation of the expression  $p \vee (\sim p \wedge q)$  is:  
 (A)  $p \leftrightarrow q$  (B)  $\sim p \vee \sim q$   
 (C)  $\sim p \wedge \sim q$  (D)  $p \wedge q$
72. A committee of 11 members is to be formed from 8 males and 5 females. If  $m$  is the number of ways the committee is formed with at least 6 males and  $n$  is the number of ways the committee is formed with at least 3 females, then:  
 (A)  $n = m - 8$  (B)  $m + n = 68$   
 (C)  $m = n = 78$  (D)  $m = n = 68$
73. If the line,  $\frac{x-1}{2} = \frac{y+1}{3} = \frac{z-2}{4}$  meets the plane,  $x + 2y + 3z = 15$  at a point  $P$ , then the distance of  $P$  from the origin is:  
 (A)  $\frac{\sqrt{5}}{2}$  (B)  $2\sqrt{5}$   
 (C)  $\frac{9}{2}$  (D)  $\frac{7}{2}$
74. The value of  $\cos^2 10^\circ - \cos 10^\circ \cos 50^\circ + \cos^2 50^\circ$  is:  
 (A)  $\frac{3}{2}(1 + \cos 20^\circ)$  (B)  $\frac{3}{4}$   
 (C)  $\frac{3}{2}$  (D)  $\frac{3}{4} + \cos 20^\circ$
75. If  $\begin{bmatrix} 1 & 1 \\ 0 & 1 \end{bmatrix} \begin{bmatrix} 1 & 2 \\ 0 & 1 \end{bmatrix} \begin{bmatrix} 1 & 3 \\ 0 & 1 \end{bmatrix} \dots \begin{bmatrix} 1 & n-1 \\ 0 & 1 \end{bmatrix} = \begin{bmatrix} 1 & 78 \\ 0 & 1 \end{bmatrix}$ , then the inverse of  $\begin{bmatrix} 1 & n \\ 0 & 1 \end{bmatrix}$  is:  
 (A)  $\begin{bmatrix} 1 & -12 \\ 0 & 1 \end{bmatrix}$  (B)  $\begin{bmatrix} 1 & 0 \\ 13 & 1 \end{bmatrix}$   
 (C)  $\begin{bmatrix} 1 & 0 \\ 12 & 1 \end{bmatrix}$  (D)  $\begin{bmatrix} 1 & -13 \\ 0 & 1 \end{bmatrix}$
76. All the points in the set  $S = \left\{ \frac{\alpha + i}{\alpha - i} : \alpha \in \mathbb{R} \right\}$  ( $i = \sqrt{-1}$ ) lie on a:  
 (A) straight line whose slope is 1 (B) circle whose radius is  $\sqrt{2}$   
 (C) straight line whose slope is  $-1$  (D) circle whose radius is 1

77. Let the sum of the first  $n$  terms of a non-constant A.P.,  $a_1, a_2, a_3, \dots$  be  $50n + \frac{n(n-7)}{2}A$ , where  $A$  is a constant. If  $d$  is the common difference of this A.P., then the ordered pair  $(d, a_{50})$  is equal to:  
 (A)  $(A, 50 + 46A)$  (B)  $(A, 50 + 45A)$   
 (C)  $(50, 50 + 45A)$  (D)  $(50, 50 + 46A)$
78. The value of  $\int_0^{\pi/2} \frac{\sin^3 x}{\sin x + \cos x} dx$  is:  
 (A)  $\frac{\pi-2}{4}$  (B)  $\frac{\pi-1}{2}$   
 (C)  $\frac{\pi-1}{4}$  (D)  $\frac{\pi-2}{8}$
79. If the line  $y = mx + 7\sqrt{3}$  is normal to the hyperbola  $\frac{x^2}{24} - \frac{y^2}{18} = 1$ , then a value of  $m$  is:  
 (A)  $\frac{2}{\sqrt{5}}$  (B)  $\frac{\sqrt{5}}{2}$   
 (C)  $\frac{\sqrt{15}}{2}$  (D)  $\frac{3}{\sqrt{5}}$
80. The solution of the differential equation  $x \frac{dy}{dx} + 2y = x^2$  ( $x \neq 0$ ) with  $y(1) = 1$ , is:  
 (A)  $y = \frac{x^3}{5} + \frac{1}{5x^2}$  (B)  $y = \frac{x^2}{4} + \frac{3}{4x^2}$   
 (C)  $y = \frac{4}{5}x^3 + \frac{1}{5x^2}$  (D)  $y = \frac{3}{4}x^2 + \frac{1}{4x^2}$
81. If one end of a focal chord of the parabola,  $y^2 = 16x$  is at  $(1, 4)$ , then the length of this focal chord is:  
 (A) 25 (B) 24  
 (C) 22 (D) 20
82. Let  $S$  be the set of all values of  $x$  for which the tangent to the curve  $y = f(x) = x^3 - x^2 - 2x$  at  $(x, y)$  is parallel to the line segment joining the points  $(1, f(1))$  and  $(-1, f(-1))$ , then  $S$  is equal to:  
 (A)  $\left\{\frac{1}{3}, -1\right\}$  (B)  $\left\{-\frac{1}{3}, -1\right\}$   
 (C)  $\left\{\frac{1}{3}, 1\right\}$  (D)  $\left\{-\frac{1}{3}, 1\right\}$



83. Slope of a line passing through  $P(2, 3)$  and intersecting the line,  $x + y = 7$  at a distance of 4 units from  $P$ , is:
- (A)  $\frac{\sqrt{5}-1}{\sqrt{5}+1}$  (B)  $\frac{1-\sqrt{5}}{1+\sqrt{5}}$   
(C)  $\frac{\sqrt{7}-1}{\sqrt{7}+1}$  (D)  $\frac{1-\sqrt{7}}{1+\sqrt{7}}$
84. Let  $\sum_{k=1}^{10} f(a+k) = 16(2^{10} - 1)$ , where the function  $f$  satisfies  $f(x+y) = f(x)f(y)$  for all natural numbers  $x, y$  and  $f(1) = 2$ . Then the natural number 'a' is:
- (A) 4 (B) 16  
(C) 2 (D) 3
85. Let  $S = \{\theta \in [-2\pi, 2\pi] : 2 \cos^2\theta + 3 \sin\theta = 0\}$ . Then the sum of the elements of  $S$  is:
- (A)  $\frac{13\pi}{6}$  (B)  $2\pi$   
(C)  $\pi$  (D)  $\frac{5\pi}{3}$
86. If a tangent to the circle  $x^2 + y^2 = 1$  intersects the coordinate axes at distinct points  $P$  and  $Q$ , then the locus of the mid-point of  $PQ$  is:
- (A)  $x^2 + y^2 - 16x^2y^2 = 0$  (B)  $x^2 + y^2 - 2x^2y^2 = 0$   
(C)  $x^2 + y^2 - 4x^2y^2 = 0$  (D)  $x^2 + y^2 - 2xy = 0$
87. Four persons can hit a target correctly with probabilities  $\frac{1}{2}, \frac{1}{3}, \frac{1}{4}$  and  $\frac{1}{8}$  respectively. If all hit at the target independently, then the probability that the target would be hit, is:
- (A)  $\frac{25}{32}$  (B)  $\frac{25}{192}$   
(C)  $\frac{7}{32}$  (D)  $\frac{1}{192}$
88. The area (in sq. units) of the region  $A = \{(x, y) : x^2 \leq y \leq x + 2\}$  is:
- (A)  $\frac{31}{6}$  (B)  $\frac{13}{6}$   
(C)  $\frac{9}{2}$  (D)  $\frac{10}{3}$
89. Let  $\alpha$  and  $\beta$  be the roots of the equation  $x^2 + x + 1 = 0$ . Then for  $y \neq 0$  in  $\mathbb{R}$ ,
- $$\begin{vmatrix} y+1 & \alpha & \beta \\ \alpha & y+\beta & 1 \\ \beta & 1 & y+\alpha \end{vmatrix}$$
- is equal to:
- (A)  $y(y^2 - 3)$  (B)  $y^3 - 1$   
(C)  $y^3$  (D)  $y(y^2 - 1)$

90. If the function  $f$  defined on  $\left(\frac{\pi}{6}, \frac{\pi}{3}\right)$  by  $f(x) = \begin{cases} \frac{\sqrt{2} \cos x - 1}{\cot x - 1}, & x \neq \frac{\pi}{4} \\ k, & x = \frac{\pi}{4} \end{cases}$  is continuous, then  $k$  is

equal to:

(A) 1

(B) 2

(C)  $\frac{1}{2}$

(D)  $\frac{1}{\sqrt{2}}$

# JEE (Main) – 2019

## ANSWERS

### PART A – PHYSICS

1.	<b>Bonus</b>	2.	<b>A</b>	3.	<b>D</b>	4.	<b>D</b>
5.	<b>B</b>	6.	<b>D</b>	7.	<b>A</b>	8.	<b>A</b>
9.	<b>A</b>	10.	<b>B</b>	11.	<b>B</b>	12.	<b>B</b>
13.	<b>B</b>	14.	<b>D</b>	15.	<b>A</b>	16.	<b>B</b>
17.	<b>D</b>	18.	<b>C</b>	19.	<b>B</b>	20.	<b>D</b>
21.	<b>C</b>	22.	<b>B</b>	23.	<b>C</b>	24.	<b>A</b>
25.	<b>B</b>	26.	<b>A</b>	27.	<b>A</b>	28.	<b>B</b>
29.	<b>D</b>	30.	<b>B</b>				

### PART B – CHEMISTRY

31.	<b>B</b>	32.	<b>A</b>	33.	<b>A</b>	34.	<b>C</b>
35.	<b>B</b>	36.	<b>A</b>	37.	<b>A</b>	38.	<b>A</b>
39.	<b>A</b>	40.	<b>D</b>	41.	<b>C</b>	42.	<b>B</b>
43.	<b>C</b>	44.	<b>C</b>	45.	<b>D</b>	46.	<b>D</b>
47.	<b>B</b>	48.	<b>B</b>	49.	<b>B</b>	50.	<b>B</b>
51.	<b>B</b>	52.	<b>C</b>	53.	<b>C</b>	54.	<b>C</b>
55.	<b>A</b>	56.	<b>D</b>	57.	<b>C</b>	58.	<b>B</b>
59.	<b>A</b>	60.	<b>D</b>				

### PART C – MATHEMATICS

61.	<b>A</b>	62.	<b>B or Bonus</b>	63.	<b>A</b>	64.	<b>D</b>
65.	<b>A</b>	66.	<b>A</b>	67.	<b>C</b>	68.	<b>A</b>
69.	<b>D</b>	70.	<b>C</b>	71.	<b>C</b>	72.	<b>C</b>
73.	<b>C</b>	74.	<b>B</b>	75.	<b>D</b>	76.	<b>D</b>
77.	<b>A</b>	78.	<b>C</b>	79.	<b>A</b>	80.	<b>B</b>
81.	<b>A</b>	82.	<b>D</b>	83.	<b>D</b>	84.	<b>D</b>
85.	<b>B</b>	86.	<b>C</b>	87.	<b>A</b>	88.	<b>C</b>
89.	<b>C</b>	90.	<b>C</b>				