

# Solutions to JEE(Main)-2019

Test Date: 12<sup>th</sup> April 2019 (First Shift)

## PHYSICS, CHEMISTRY & MATHEMATICS

Paper - 1

Time Allotted: 3 Hours

Maximum Marks: 360

- Please read the instructions carefully. You are allotted 5 minutes specifically for this purpose.

### **Important Instructions:**

1. The test is of **3 hours** duration.
2. This **Test Paper** consists of **90** questions. The maximum marks are **360**.
3. There are **three** parts in the question paper A, B, C consisting of **Physics, Chemistry** and **Mathematics** having 30 questions in each part of equal weightage. Each question is allotted **4 (four)** marks for correct response.
4. Out of the four options given for each question, only one option is the correct answer.
5. For each incorrect response 1 mark i.e.  $\frac{1}{4}$  (**one-fourth**) marks of the total marks allotted to the question will be deducted from the total score. No deduction from the total score, however, will be made if no response is indicated for an item in the Answer Box.
6. *Candidates will be awarded marks as stated above in **instruction No.3** for correct response of each question. One mark will be deducted for indicating incorrect response of each question. No deduction from the total score will be made if no response is indicated for an item in the answer box.*
7. There is only one correct response for each question. Marked up more than one response in any question will be treated as wrong response and marked up for wrong response will be deducted accordingly as per **instruction 6** above.

## PART –A (PHYSICS)

1. The value of numerical aperture of the objective lens of a microscope is 1.25. If light of wavelength  $5000 \text{ \AA}$  is used, the minimum separation between two points, to be seen as distinct, will be :
- (A)  $0.48 \text{ \mu m}$  (B)  $0.38 \text{ \mu m}$   
 (C)  $0.24 \text{ \mu m}$  (D)  $0.12 \text{ \mu m}$

2. The resistive network shown below is connected to a D.C. source of 16 V. The power consumed by the network is 4 Watt. The value of R is:

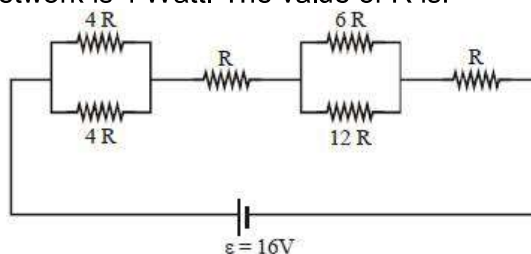

- (A)  $8 \text{ \Omega}$  (B)  $6 \text{ \Omega}$   
 (B)  $16 \text{ \Omega}$  (D)  $1 \text{ \Omega}$
3. The figure shows a square loop L of side 5 cm which is connected to a network of resistances. The whole set up is moving towards right with a constant speed of  $1 \text{ cm s}^{-1}$ . At some instant, a part of L is in a uniform magnetic field of 1 T, perpendicular to the plane of the loop. If the resistance of L is  $1.7 \text{ \Omega}$ , the current in the loop at that instant will be close to :

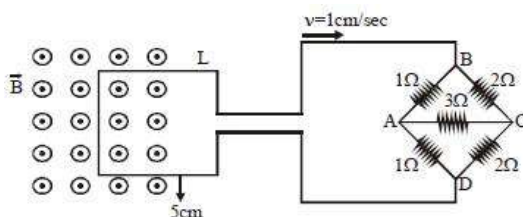

- (A)  $115 \text{ \mu A}$  (B)  $170 \text{ \mu A}$   
 (C)  $60 \text{ \mu A}$  (D)  $150 \text{ \mu A}$

4. A circular disc of radius b has a hole of radius a at its centre (see figure). If the mass per unit area of the disc varies as  $\left(\frac{\sigma_0}{r}\right)$ , then the radius of gyration of the disc about its axis passing through the centre is :

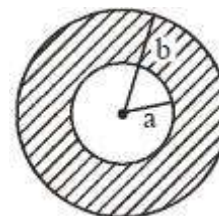

- (A)  $\frac{a+b}{3}$  (B)  $\sqrt{\frac{a^2 + b^2 + ab}{3}}$   
 (C)  $\frac{a+b}{2}$  (D)  $\sqrt{\frac{a^2 + b^2 + ab}{2}}$

5. A man (mass = 50 kg) and his son (mass = 20 kg) are standing on a frictionless surface facing each other. The man pushes his son so that he starts moving at a speed of  $0.70 \text{ ms}^{-1}$  with respect to the man. The speed of the man with respect to the surface is :  
 (A)  $0.47 \text{ ms}^{-1}$  (B)  $0.28 \text{ ms}^{-1}$   
 (C)  $0.14 \text{ ms}^{-1}$  (D)  $0.20 \text{ ms}^{-1}$
6. Two identical parallel plate capacitors, of capacitance  $C$  each, have plates of area  $A$ , separated by a distance  $d$ . The space between the plates of the two capacitors, is filled with three dielectrics, of equal thickness and dielectric constants  $K_1$ ,  $K_2$  and  $K_3$ . The first capacitor is filled as shown in fig. I, and the second one is filled as shown in fig. II. If these two modified capacitors are charged by the same potential  $V$ , the ratio of the energy stored in the two, would be ( $E_1$  refers to capacitor (I) and  $E_2$  to capacitor (II)) :

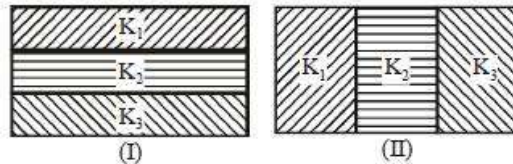

- (A)  $\frac{E_1}{E_2} = \frac{K_1 K_2 K_3}{(K_1 + K_2 + K_3)(K_2 K_3 + K_3 K_1 + K_1 K_2)}$  (B)  $\frac{E_1}{E_2} = \frac{9K_1 K_2 K_3}{(K_1 + K_2 + K_3)(K_2 K_3 + K_3 K_1 + K_1 K_2)}$   
 (C)  $\frac{E_1}{E_2} = \frac{(K_1 + K_2 + K_3)(K_2 K_3 + K_3 K_1 + K_1 K_2)}{9K_1 K_2 K_3}$  (D)  $\frac{E_1}{E_2} = \frac{(K_1 + K_2 + K_3)(K_2 K_3 + K_3 K_1 + K_1 K_2)}{K_1 K_2 K_3}$

7. Two moles of helium gas is mixed with three moles of hydrogen molecules (taken to be rigid). What is the molar specific heat of mixture at constant volume? ( $R = 8.3 \text{ J/mol K}$ )  
 (A)  $17.4 \text{ J/mol K}$  (B)  $15.7 \text{ J/mol K}$   
 (C)  $19.7 \text{ J/mol K}$  (D)  $21.6 \text{ J/mol K}$

8. The stopping potential  $V_0$  (in volt) as a function of frequency ( $\nu$ ) for a sodium emitter, is shown in the figure. The work function of sodium, from the data plotted in the figure, will be :

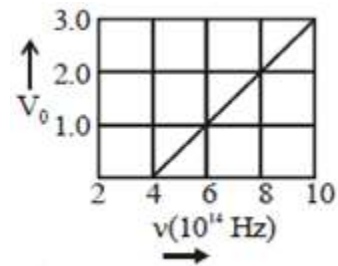

- (Given : Planck's constant ( $h$ ) =  $6.63 \times 10^{-34} \text{ Js}$ , electron charge  $e = 1.6 \times 10^{-19} \text{ C}$ )  
 (A)  $1.82 \text{ eV}$  (B)  $1.66 \text{ eV}$   
 (C)  $2.12 \text{ eV}$  (D)  $1.95 \text{ eV}$

9. At  $40^\circ\text{C}$ , a brass wire of  $1 \text{ mm}$  is hung from the ceiling. A small mass,  $M$  is hung from the free end of the wire. When the wire is cooled down from  $40^\circ\text{C}$  to  $20^\circ\text{C}$  it regains its original length of  $0.2 \text{ m}$ . The value of  $M$  is close to :

(Coefficient of linear expansion and Young's modulus of brass are  $10^{-5}/^\circ\text{C}$  and  $10^{11} \text{ N/m}^2$ , respectively;  $g = 10 \text{ ms}^{-2}$ )

- (A)  $0.5 \text{ kg}$  (B)  $9 \text{ kg}$   
 (C)  $0.9 \text{ kg}$  (D)  $1.5 \text{ kg}$

10. A magnetic compass needle oscillates 30 times per minute at a place where the dip is  $45^\circ$ , and 40 times per minute where the dip is  $30^\circ$ . If  $B_1$  and  $B_2$  are respectively the total magnetic field due to the earth at the two places, then the ratio  $B_1/B_2$  is best given by :

- (A) 3.6 (B) 1.8  
 (C) 2.2 (D) 0.7

11. An excited  $\text{He}^+$  ion emits two photons in succession, with wavelengths 108.5 nm and 30.4 nm, in making a transition to ground state. The quantum number  $n$ , corresponding to its initial excited state is (for photon of wavelength  $\lambda$ , energy  $E = \frac{1240 \text{ eV}}{\lambda(\text{in nm})}$  :)
- (A)  $n = 4$  (B)  $n = 6$   
 (C)  $n = 5$  (D)  $n = 7$
12. When  $M_1$  gram of ice at  $-10^\circ\text{C}$  (specific heat =  $0.5 \text{ cal g}^{-1}\text{C}^{-1}$ ) is added to  $M_2$  gram of water at  $50^\circ\text{C}$ , finally no ice is left and the water is at  $0^\circ\text{C}$ . The value of latent heat of ice, in  $\text{cal g}^{-1}$  is:
- (A)  $\frac{50M_2}{M_1} - 5$  (B)  $\frac{5M_2}{M_1} - 5$   
 (C)  $\frac{50M_2}{M_1}$  (D)  $\frac{5M_1}{M_2} - 50$
13. A shell is fired from a fixed artillery gun with an initial speed  $u$  such that it hits the target on the ground at a distance  $R$  from it. If  $t_1$  and  $t_2$  are the values of the time taken by it to hit the target in two possible ways, the product  $t_1 t_2$  is:
- (A)  $2R / g$  (B)  $R / 4g$   
 (C)  $R / g$  (D)  $R/2g$
14. The transfer characteristic curve of a transistor, having input and output resistance  $100 \Omega$  and  $100 \text{ k}\Omega$  respectively, is shown in the figure. The Voltage and Power gain, are respectively :

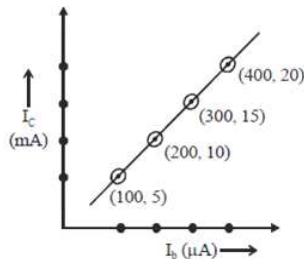

- (A)  $5 \times 10^4, 2.5 \times 10^6$  (B)  $5 \times 10^4, 5 \times 10^6$   
 (C)  $5 \times 10^4, 5 \times 10^5$  (D)  $2.5 \times 10^4, 2.5 \times 10^6$

15. Shown in the figure is a shell made of a conductor. It has inner radius  $a$  and outer radius  $b$ , and carries charge  $Q$ . At its centre is a dipole  $\vec{P}$  as shown. In this case :

- (A) Surface charge density on the inner surface of the shell is zero everywhere.  
 (B) Electric field outside the shell is the same as that of a point charge at the centre of the shell.  
 (C) Surface charge density on the inner surface is uniform and equal to  $\frac{(Q/2)}{4\pi a^2}$   
 (D) Surface charge density on the outer surface depends on  $|\vec{P}|$

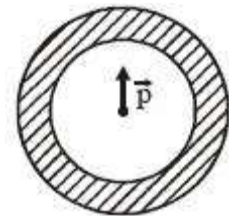

16. Which of the following combinations has the dimension of electrical resistance ( $\epsilon_0$  is the permittivity of vacuum and  $\mu_0$  is the permeability of vacuum)?

(A)  $\sqrt{\frac{\epsilon_0}{\mu_0}}$

(B)  $\frac{\mu_0}{\epsilon_0}$

(C)  $\frac{\epsilon_0}{\mu_0}$

(D)  $\sqrt{\frac{\mu_0}{\epsilon_0}}$

17. A galvanometer of resistance  $100 \Omega$  has 50 divisions on its scale and has sensitivity of  $20 \mu\text{A} / \text{division}$ . It is to be converted to a voltmeter with three ranges, of 0–2 V, 0–10 V and 0–20 V. The appropriate circuit to do so is :

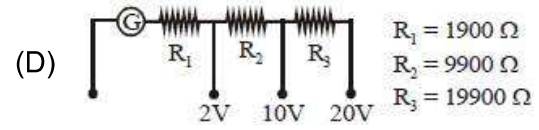
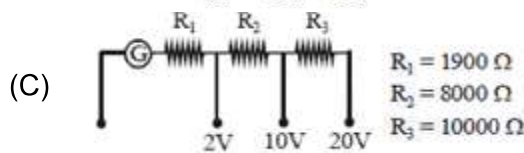
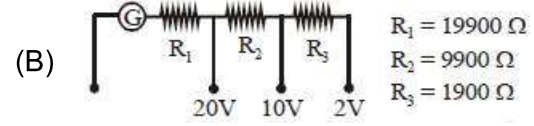
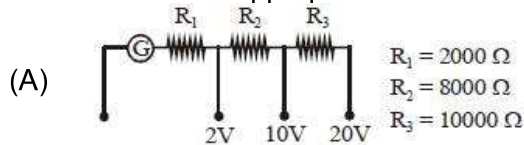

18. In a double slit experiment, when a thin film of thickness  $t$  having refractive index  $\mu$  is introduced in front of one of the slits, the maximum at the centre of the fringe pattern shifts by one fringe width. The value of  $t$  is ( $\lambda$  is the wavelength of the light used) :

(A)  $\frac{\lambda}{2(\mu - 1)}$

(B)  $\frac{\lambda}{(\mu - 1)}$

(C)  $\frac{\lambda}{(2\mu - 1)}$

(D)  $\frac{2\lambda}{(\mu - 1)}$

19. A progressive wave travelling along the positive  $x$ -direction is represented by  $y(x, t) = A \sin(kx - \omega t + \phi)$ . Its snapshot at  $t = 0$  is given in the figure:

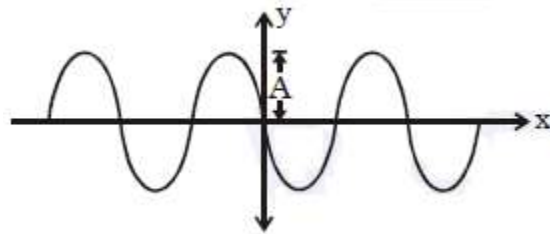

For this wave, the phase  $\phi$  is :

(A)  $\pi$

(B)  $\frac{\pi}{2}$

(C)  $-\frac{\pi}{2}$

(D) 0

20. A uniform rod of length  $\ell$  is being rotated in a horizontal plane with a constant angular speed about an axis passing through one of its ends. If the tension generated in the rod due to rotation is  $T(x)$  at a distance  $x$  from the axis, then which of the following graphs depicts it most closely?

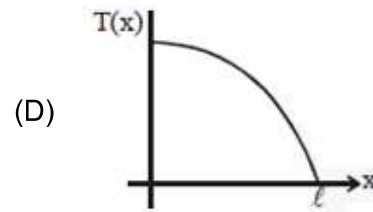
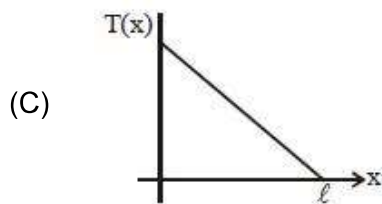
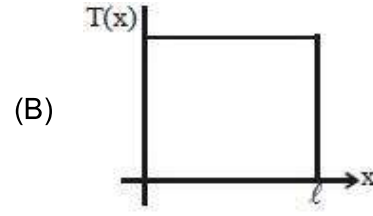
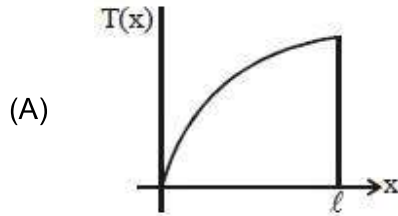

21. A point dipole  $\vec{p} = -p_0 \hat{x}$  is kept at the origin. The potential and electric field due to this dipole on the  $y$ -axis at a distance  $d$  are, respectively : (Take  $V = 0$  at infinity)

(A)  $\frac{|\vec{p}|}{4\pi\epsilon_0 d^2}, \frac{-\vec{p}}{4\pi\epsilon_0 d^3}$

(B)  $0, \frac{\vec{p}}{4\pi\epsilon_0 d^3}$

(C)  $\frac{|\vec{p}|}{4\pi\epsilon_0 d^2}, \frac{\vec{p}}{4\pi\epsilon_0 d^3}$

(D)  $0, \frac{-\vec{p}}{4\pi\epsilon_0 d^3}$

22. An electromagnetic wave is represented by the electric field  $\vec{E} = E_0 \hat{n} \sin[\omega t + (6y - 8z)]$ . Taking unit vectors in  $x, y$  and  $z$  directions to be  $\hat{i}, \hat{j}, \hat{k}$ , the direction of propagation  $\hat{s}$ , is :

(A)  $\hat{S} = \left( \frac{-3\hat{j} + 4\hat{k}}{5} \right)$

(B)  $\hat{S} = \left( \frac{4\hat{j} - 3\hat{k}}{5} \right)$

(C)  $\hat{S} = \left( \frac{-4\hat{k} + 3\hat{j}}{5} \right)$

(D)  $\hat{S} = \left( \frac{-3\hat{i} - 4\hat{j}}{5} \right)$

23. A submarine (A) travelling at 18 km/hr is being chased along the line of its velocity by another submarine (B) travelling at 27 km/hr. B sends a sonar signal of 500 Hz to detect A and receives a reflected sound of frequency  $\nu$ . The value of  $\nu$  is close to : (Speed of sound in water = 1500 ms<sup>-1</sup>)

(A) 499 Hz

(B) 502 Hz

(C) 504 Hz

(D) 507 Hz

24. The trajectory of a projectile near the surface of the earth is given as  $y = 2x - 9x^2$ . If it were launched at an angle  $\theta_0$  with speed  $v_0$  then ( $g = 10 \text{ ms}^{-2}$ ) :

- (A)  $\theta_0 = \cos^{-1}\left(\frac{1}{\sqrt{5}}\right)$  and  $v_0 = \frac{5}{3} \text{ ms}^{-1}$       (B)  $\theta_0 = \cos^{-1}\left(\frac{2}{\sqrt{5}}\right)$  and  $v_0 = \frac{3}{5} \text{ ms}^{-1}$   
 (C)  $\theta_0 = \sin^{-1}\left(\frac{2}{\sqrt{5}}\right)$  and  $v_0 = \frac{3}{5} \text{ ms}^{-1}$       (D)  $\theta_0 = \sin^{-1}\left(\frac{1}{\sqrt{5}}\right)$  and  $v_0 = \frac{5}{3} \text{ ms}^{-1}$

25. A thin ring of 10 cm radius carries a uniformly distributed charge. The ring rotates at a constant angular speed of  $40\pi \text{ rad s}^{-1}$  about its axis, perpendicular to its plane. If the magnetic field at its centre is  $3.8 \times 10^{-9} \text{ T}$ , then the charge carried by the ring is close to ( $\mu_0 = 4\pi \times 10^{-7} \text{ N/A}^2$ ).

- (A)  $2 \times 10^{-6} \text{ C}$       (B)  $7 \times 10^{-6} \text{ C}$   
 (C)  $4 \times 10^{-5} \text{ C}$       (D)  $3 \times 10^{-5} \text{ C}$

26. The truth table for the circuit given in the fig is :

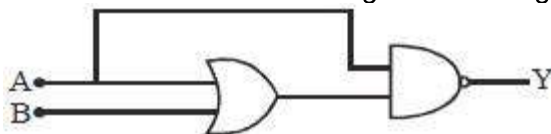

(A) 

A	B	Y
0	0	1
0	1	0
1	0	0
1	1	0

(B) 

A	B	Y
0	0	0
0	1	0
1	0	1
1	1	1

(C) 

A	B	Y
0	0	1
0	1	1
1	0	1
1	1	1

(D) 

A	B	Y
0	0	1
0	1	1
1	0	0
1	1	0

27. A sample of an ideal gas is taken through the cyclic process abca as shown in the figure. The change in the internal energy of the gas along the path ca is  $-180 \text{ J}$ . The gas absorbs  $250 \text{ J}$  of heat along the path ab and  $60 \text{ J}$  along the path bc. The work done by the gas along the path abc is :

- (A)  $120 \text{ J}$       (B)  $100 \text{ J}$   
 (C)  $140 \text{ J}$       (D)  $130 \text{ J}$

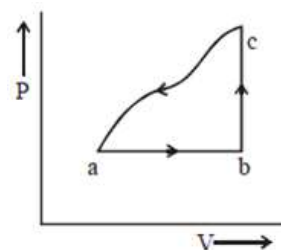

28. A concave mirror has radius of curvature of 40 cm. It is at the bottom of a glass that has water filled up to 5 cm (see figure). If a small particle is floating on the surface of water, its image as seen, from directly above the glass, is at a distance  $d$  from the surface of water. The value of  $d$  is close to : (Refractive index of water = 1.33)

- (A) 13.4 cm (B) 8.8 cm  
(C) 6.7 cm (D) 11.7 cm

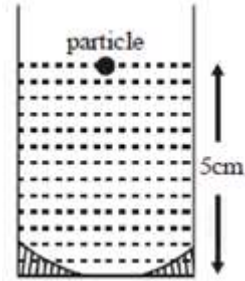

29. To verify Ohm's law, a student connects the voltmeter across the battery as, shown in the figure. The measured voltage is plotted as a function of the current, and the following graph is obtained:

If  $V_0$  is almost zero, identify the correct statement:

- (A) The potential difference across the battery is 1.5 V when it sends a current of 1000 mA.  
(B) The emf of the battery is 1.5 V and the value of  $R$  is  $1.5 \Omega$   
(C) The emf of the battery is 1.5 V and its internal resistance is  $1.5 \Omega$   
(D) The value of the resistance  $R$  is  $1.5 \Omega$

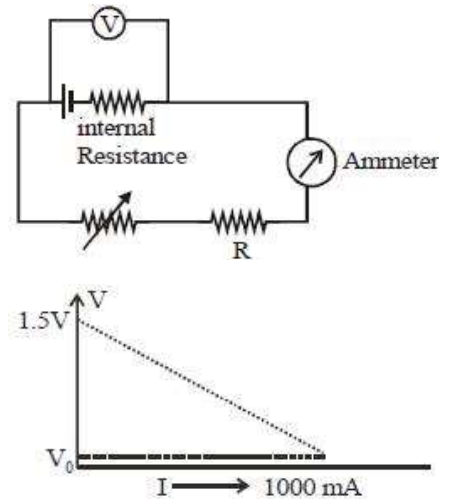

30. A person of mass  $M$  is, sitting on a swing of length  $L$  and swinging with an angular amplitude  $\theta_0$ . If the person stands up when the swing passes through its lowest point, the work done by him, assuming that his centre of mass moves by a distance  $\ell$  ( $\ell \ll L$ ), is close to :

- (A)  $Mg\ell(1 + \theta_0^2)$  (B)  $Mg\ell(1 - \theta_0^2)$   
(C)  $Mg\ell$  (D)  $Mg\ell\left(1 + \frac{\theta_0^2}{2}\right)$



## PART –B (CHEMISTRY)

31. The mole fraction of a solvent in aqueous solution of a solute is 0.8. The molality (in mol kg<sup>-1</sup>) of the aqueous solution is  
 (A)  $13.88 \times 10^{-2}$  (B)  $13.88 \times 10^{-1}$   
 (C) 13.88 (D)  $13.88 \times 10^{-3}$

32. The major products of the following reaction are:

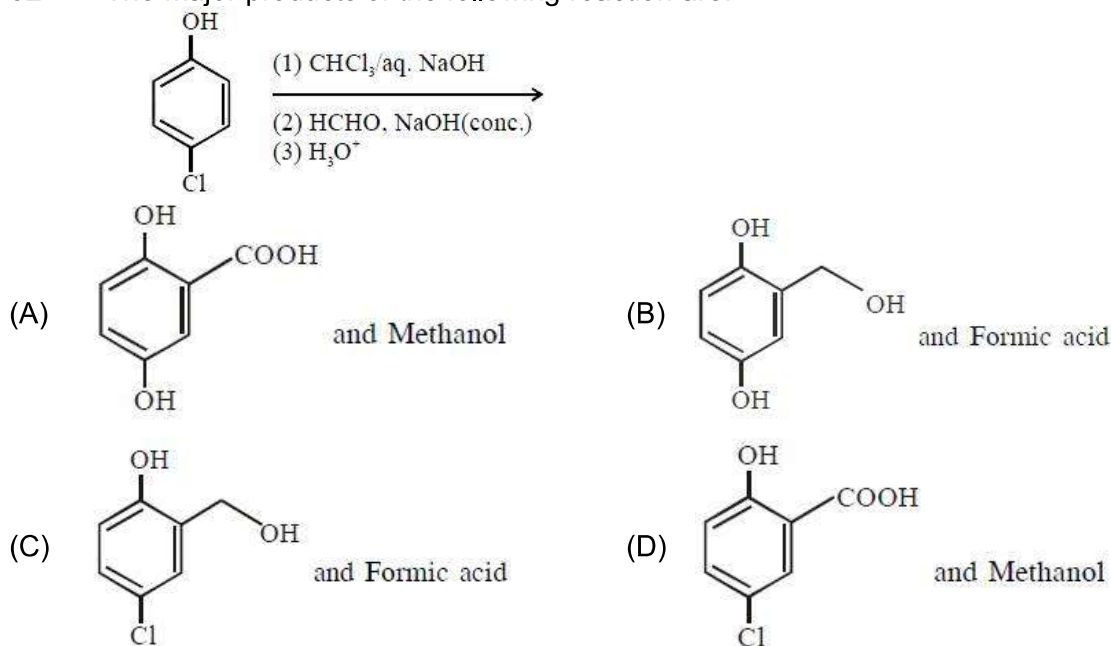

33. The correct statement among the following is  
 (A) (SiH<sub>3</sub>)<sub>3</sub>N is planar and less basic than (CH<sub>3</sub>)<sub>3</sub>N.  
 (B) (SiH<sub>3</sub>)<sub>3</sub>N is planar and more basic than (CH<sub>3</sub>)<sub>3</sub>N.  
 (C) (SiH<sub>3</sub>)<sub>3</sub>N is pyramidal and less basic than (CH<sub>3</sub>)<sub>3</sub>N.  
 (D) (SiH<sub>3</sub>)<sub>3</sub>N is pyramidal and more basic than (CH<sub>3</sub>)<sub>3</sub>N.
34. The complex ion that will lose its crystal field stabilization energy upon oxidation of its metal to +3 state is

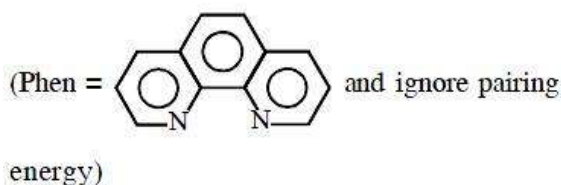

- (A) [Ni(phen)<sub>3</sub>]<sup>2+</sup> (B) [Zn(phen)<sub>3</sub>]<sup>2+</sup>  
 (C) [Co(phen)<sub>3</sub>]<sup>2+</sup> (D) [Fe(phen)<sub>3</sub>]<sup>2+</sup>

35. The correct set of species responsible for the photochemical smog is :  
 (A) NO, NO<sub>2</sub>, O<sub>3</sub> and hydrocarbons (B) CO<sub>2</sub>, NO<sub>2</sub>, SO<sub>2</sub> and hydrocarbons  
 (C) N<sub>2</sub>, NO<sub>2</sub> and hydrocarbons (D) N<sub>2</sub>, O<sub>2</sub>, O<sub>3</sub> and hydrocarbons

36. The major product(s) obtained in the following reaction is/ are:

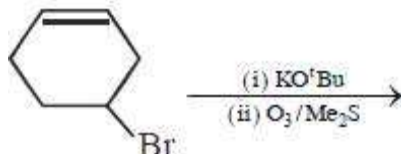

- (A) O=CC=CC=CC=O (B) O=CC(OBu)CC=O  
 (C) O=CC=O and O=CC=O (D) O=CC=O

37. The major product of the following addition reaction is:

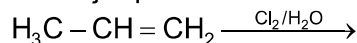

- (A) CC(Cl)C(O)C (B) CC(=O)C  
 (C) CC(O)C(Cl)C (D) CC1OC1

38. The correct sequence of thermal stability of the following carbonates is :  
 (A) BaCO<sub>3</sub> < SrCO<sub>3</sub> < CaCO<sub>3</sub> < MgCO<sub>3</sub> (B) BaCO<sub>3</sub> < CaCO<sub>3</sub> < SrCO<sub>3</sub> < MgCO<sub>3</sub>  
 (C) MgCO<sub>3</sub> < CaCO<sub>3</sub> < SrCO<sub>3</sub> < BaCO<sub>3</sub> (D) MgCO<sub>3</sub> < SrCO<sub>3</sub> < CaCO<sub>3</sub> < BaCO<sub>3</sub>

39. The group number, number of valence electrons and valency of an element with atomic number 15, respectively, are:

- (A) 15, 5 and 3 (B) 15, 6 and 2  
 (C) 16, 5 and 2 (D) 16, 6 and 3

40. Peptization is a :

- (A) process of converting soluble particles to form colloidal solution  
 (B) process of converting precipitate into colloidal solution  
 (C) process of converting a colloidal solution into precipitate  
 (D) process of bringing colloidal molecule into solution

41. The metal that gives hydrogen gas upon treatment with both acid as well as base is:

- (A) iron (B) magnesium  
 (C) zinc (D) mercury

42. The electrons are more likely to be found:

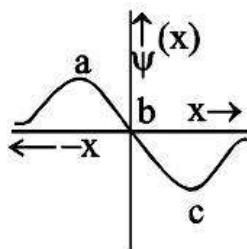

- (A) in the region a and b  
(B) in the region a and c  
(C) only in the region a  
(D) only in the region c
43. An example of a disproportionation reaction is :  
(A)  $2\text{KMnO}_4 \longrightarrow \text{K}_2\text{MnO}_4 + \text{MnO}_2 + \text{O}_2$   
(B)  $2\text{NaBr} + \text{Cl}_2 \longrightarrow 2\text{NaCl} + \text{Br}_2$   
(C)  $2\text{CuBr} \longrightarrow \text{CuBr}_2 + \text{Cu}$   
(D)  $2\text{MnO}_4^- + 10\text{I}^- + 16\text{H}^+ \longrightarrow 2\text{Mn}^{2+} + 5\text{I}_2 + 8\text{H}_2\text{O}$
44. 5 moles of  $\text{AB}_2$  weigh  $125 \times 10^{-3}$  kg and 10 moles of  $\text{A}_2\text{B}_2$  weigh  $300 \times 10^{-3}$  kg. The molar mass of A ( $M_A$ ) and molar mass of B ( $M_B$ ) in  $\text{kg mol}^{-1}$  are :  
(A)  $M_A = 50 \times 10^{-3}$  and  $M_B = 25 \times 10^{-3}$   
(B)  $M_A = 10 \times 10^{-3}$  and  $M_B = 5 \times 10^{-3}$   
(C)  $M_A = 5 \times 10^{-3}$  and  $M_B = 10 \times 10^{-3}$   
(D)  $M_A = 25 \times 10^{-3}$  and  $M_B = 50 \times 10^{-3}$
45. The basic structural unit of feldspar, zeolites, mica and asbestos is :  
(A)  $\begin{array}{c} \text{R} \\ | \\ \text{-(Si-O)}_n \\ | \\ \text{R} \end{array}$  (R=Me)  
(B)  $(\text{SiO}_3)^{2-}$   
(C)  $\text{SiO}_2$   
(D)  $(\text{SiO}_4)^{4-}$
46. Enthalpy of sublimation of iodine is  $24 \text{ cal g}^{-1}$  at  $200^\circ\text{C}$ . If specific heat of  $\text{I}_2(\text{s})$  and  $\text{I}_2(\text{vap})$  are  $0.055$  and  $0.031 \text{ cal g}^{-1}\text{K}^{-1}$  respectively, then enthalpy of sublimation of iodine at  $250^\circ\text{C}$  in  $\text{cal g}^{-1}$  is :  
(A) 2.85  
(B) 11.4  
(C) 5.7  
(D) 22.8
47. Which of the following is a thermosetting polymer?  
(A) PVC  
(B) Bakelite  
(C) Buna-N  
(D) Nylon 6
48. An element has a face-centred cubic (fcc) structure with a cell edge of  $a$ . The distance between the centres of two nearest tetrahedral voids in the lattice is:  
(A)  $\frac{a}{2}$   
(B)  $\sqrt{2}a$   
(C)  $\frac{3}{2}a$   
(D)  $a$

49. An organic compound 'A' is oxidized with  $\text{Na}_2\text{O}_2$  followed by boiling with  $\text{HNO}_3$ . The resultant solution is then treated with ammonium molybdate to yield a yellow precipitate. Based on above observation, the element present in the given compound is :

- (A) Phosphorus (B) Sulphur  
(C) Nitrogen (D) Fluorine

50. The idea of froth floatation method came from a person X and this method is related to the process Y of ores. X and Y, respectively, are:

- (A) washer woman and concentration (B) fisher woman and concentration  
(C) fisher man and reduction (D) washer man and reduction

51. In the following reaction;  $x\text{A} \longrightarrow y\text{B}$

$$\log_{10} \left[ -\frac{d[\text{A}]}{dt} \right] = \log_{10} \left[ \frac{d[\text{B}]}{dt} \right] + 0.3010$$

'A' and 'B' respectively can be :

- (A)  $\text{C}_2\text{H}_2$  and  $\text{C}_6\text{H}_6$  (B) n-Butane and Iso-butane  
(C)  $\text{N}_2\text{O}_4$  and  $\text{NO}_2$  (D)  $\text{C}_2\text{H}_4$  and  $\text{C}_4\text{H}_8$

52. Glucose and Galactose are having identical configuration in all the positions except position.

- (A) C-4 (B) C-3  
(C) C-5 (D) C-2

53. Which of the following statements is not true about RNA?

- (A) It has always double stranded  $\alpha$ -helix structure  
(B) It is present in the nucleus of the cell  
(C) It controls the synthesis of protein  
(D) It usually does not replicate

54. What is the molar solubility of  $\text{Al}(\text{OH})_3$  in 0.2 M NaOH solution? Given that, solubility product of  $\text{Al}(\text{OH})_3 = 2.4 \times 10^{-24}$  :

- (A)  $3 \times 10^{-19}$  (B)  $12 \times 10^{-21}$   
(C)  $12 \times 10^{-23}$  (D)  $3 \times 10^{-22}$

55. The increasing order of the  $\text{pK}_b$  of the following compound is :

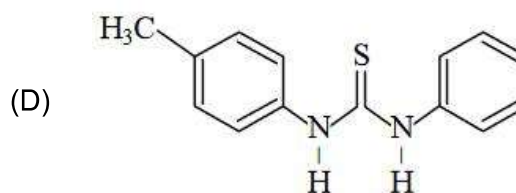
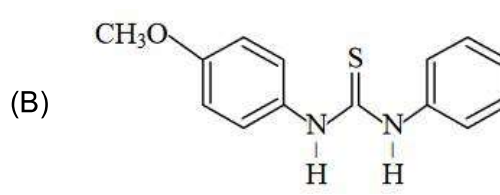
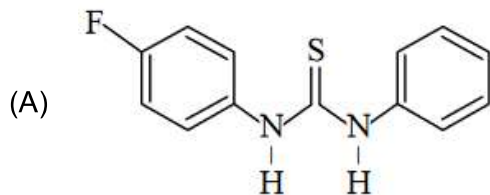

- (A) (c) < (a) < (d) < (b)  
(C) (a) < (c) < (d) < (b)

- (B) (b) < (d) < (a) < (c)  
(D) (b) < (d) < (c) < (a)

56.

Given :

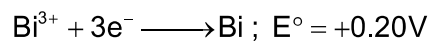
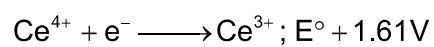
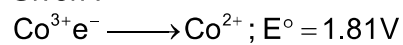

Oxidizing power of the species will increase in the order

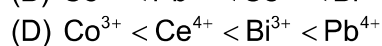
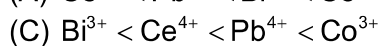
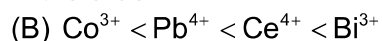
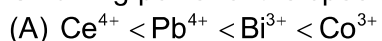

57.

But-2-ene on reaction with alkaline  $\text{KMnO}_4$  at elevated temperature followed by acidification will give :

(A) One molecule of  $\text{CH}_3\text{CHO}$  and one molecule of  $\text{CH}_3\text{COOH}$

(B) 2 molecules of  $\text{CH}_3\text{CHO}$

(C) 2 molecules of  $\text{CH}_3\text{COOH}$

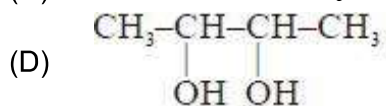

58.

The major product of the following reaction is :

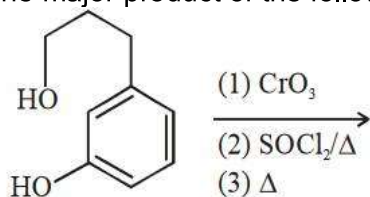

(A)

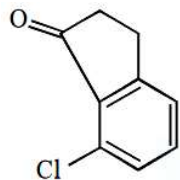

(B)

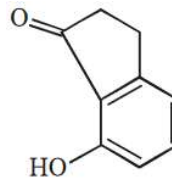

(C)

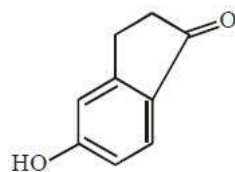

(D)

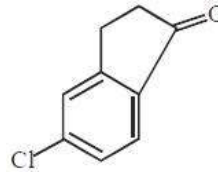

59. Complete removal of both the axial ligands (along the z-axis) from an octahedral complex leads to which of the following splitting patterns? (relative orbital energies not on scale).

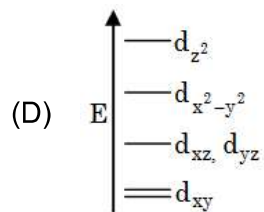
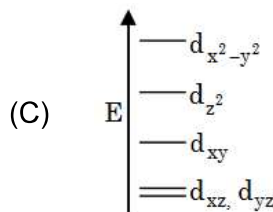
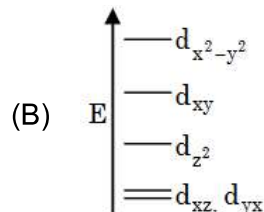
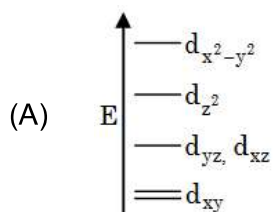

60. An ideal gas is allowed to expand from 1 L to 10 L against a constant external pressure of 1 bar. The work done in kJ is:  
 (A) - 9.0 (B) - 0.9  
 (C) - 2.0 (D) + 10.0

## **PART-C (MATHEMATICS)**

61. Let P be the point of intersection of the common tangents to the parabola  $y^2 = 12x$  and the hyperbola  $8x^2 - y^2 = 8$ . If S and S' denote the foci of the hyperbola where S lies on the positive x-axis then P divides SS' in a ratio:  
(A) 2:1 (B) 13:11  
(C) 5:4 (D) 14:13
62. If three of the six vertices of a regular hexagon are chosen at random, then the probability that the triangle formed with these chosen vertices is equilateral is :  
(A)  $\frac{3}{10}$  (B)  $\frac{1}{5}$   
(C)  $\frac{1}{10}$  (D)  $\frac{3}{20}$
63. Let  $f : \mathbb{R} \rightarrow \mathbb{R}$  be a continuously differentiable function such that  $f(2) = 6$  and  $f'(2) = \frac{1}{48}$ . If  $\int_6^{f(x)} 4t^3 dt = (x-2)g(x)$ , then  $\lim_{x \rightarrow 2} g(x)$  is equal to :  
(A) 24 (B) 18  
(C) 12 (D) 36
64. The integral  $\int \frac{2x^3 - 1}{x^4 + x} dx$  is equal to :  
(Here C is a constant of integration)  
(A)  $\frac{1}{2} \log_e \left| \frac{x^3 + 1}{x^2} \right| + C$  (B)  $\frac{1}{2} \log_e \left| \frac{x^3 + 1}{x^3} \right|^2 + C$   
(C)  $\log_e \left| \frac{x^3 + 1}{x} \right| + C$  (D)  $\log_e \left| \frac{x^3 + 1}{x^2} \right| + C$
65. The coefficient of  $x^{18}$  in the product  $(1+x)(1-x)^{10}(1+x+x^2)^9$  is :  
(A) 84 (B) 126  
(C) -126 (D) -84
66. The number of ways of choosing 10 objects out of 31 objects of which 10 are identical and the remaining 21 are distinct, is :  
(A)  $2^{20}$  (B)  $2^{20} + 1$   
(C)  $2^{21}$  (D)  $2^{20} - 1$
67. Let a random variable X have a binomial distribution with mean 8 and variance 4. If  $P(X \leq 2) = \frac{k}{2^{16}}$ , then k is equal to :  
(A) 17 (B) 137  
(C) 1 (D) 121

68. The equation  $|z - i| = |z - 1|$ ,  $i = \sqrt{-1}$ , represents :
- (A) a circle of radius  $\frac{1}{2}$  (B) the line through the origin with slope 1  
 (C) a circle of radius 1 (D) the line through the origin with slope  $-1$
69. If  $m$  is the minimum value of  $k$  for which the function  $f(x) = x\sqrt{kx - x^2}$  is increasing in the interval  $[0, 3]$  and  $M$  is the maximum value of  $f$  in  $[0, 3]$  when  $k = m$ , then the ordered pair  $(m, M)$  is equal to :
- (A)  $(5, 3\sqrt{6})$  (B)  $(4, 3\sqrt{2})$   
 (C)  $(3, 3\sqrt{3})$  (D)  $(4, 3\sqrt{3})$
70. If the data  $x_1, x_2, \dots, x_{10}$  is such that the mean of first four of these is 11, the mean of the remaining six is 16 and the sum of squares of all of these is 2,000; then the standard deviation of this data is :
- (A)  $2\sqrt{2}$  (B) 2  
 (C) 4 (D)  $\sqrt{2}$
71. If the area (in sq. units) of the region  $\{(x, y) : y^2 \leq 4x, x + y \leq 1, x \geq 0, y \geq 0\}$  is  $a\sqrt{2} + b$ , then  $a - b$  is equal to :
- (A)  $\frac{10}{3}$  (B) 6  
 (C)  $\frac{8}{3}$  (D)  $-\frac{2}{3}$
72. Consider the differential equation,  $y^2 dx + \left(x - \frac{1}{y}\right) dy = 0$ . If value of  $y$  is 1 when  $x = 1$ , then the value of  $x$  for which  $y = 2$ , is :
- (A)  $\frac{3}{2} - \sqrt{e}$  (B)  $\frac{1}{2} + \frac{1}{\sqrt{e}}$   
 (C)  $\frac{3}{2} - \frac{1}{\sqrt{e}}$  (D)  $\frac{5}{2} + \frac{1}{\sqrt{e}}$
73. If  $\alpha$  and  $\beta$  are the roots of the equation  $375x^2 - 25x - 2 = 0$ , then  $\lim_{n \rightarrow \infty} \sum_{r=1}^n \alpha^r + \lim_{n \rightarrow \infty} \sum_{r=1}^n \beta^r$  is equal to :
- (A)  $\frac{1}{12}$  (B)  $\frac{29}{358}$   
 (C)  $\frac{7}{116}$  (D)  $\frac{21}{346}$



74. A 2 m ladder leans against a vertical wall. If the top of the ladder begins to slide down the wall at the rate 25 cm/ sec., then the rate (in cm/sec.) at which the bottom of the ladder slides away from the wall on the horizontal ground when the top of the ladder is 1 m above the ground is :
- (A) 25 (B)  $\frac{25}{3}$   
(C)  $25\sqrt{3}$  (D)  $\frac{25}{\sqrt{3}}$
75. The number of solutions of the equation  $1 + \sin^4 x = \cos^2 3x$ ,  $x \in \left[-\frac{5\pi}{2}, \frac{5\pi}{2}\right]$  is :
- (A) 3 (B) 4  
(C) 5 (D) 7
76. If  $e^y + xy = e$ , the ordered pair  $\left(\frac{dy}{dx}, \frac{d^2y}{dx^2}\right)$  at  $x = 0$  is equal to :
- (A)  $\left(\frac{1}{e}, -\frac{1}{e^2}\right)$  (B)  $\left(\frac{1}{e}, \frac{1}{e^2}\right)$   
(C)  $\left(-\frac{1}{e}, \frac{1}{e^2}\right)$  (D)  $\left(-\frac{1}{e}, -\frac{1}{e^2}\right)$
77. The value of  $\sin^{-1}\left(\frac{12}{13}\right) - \sin^{-1}\left(\frac{3}{5}\right)$  is equal to :
- (A)  $\pi - \cos^{-1}\left(\frac{33}{65}\right)$  (B)  $\pi - \sin^{-1}\left(\frac{63}{65}\right)$   
(C)  $\frac{\pi}{2} - \cos^{-1}\left(\frac{9}{65}\right)$  (D)  $\frac{\pi}{2} - \sin^{-1}\left(\frac{56}{65}\right)$
78. If the normal to the ellipse  $3x^2 + 4y^2 = 12$  at a point P on it is parallel to the line,  $2x + y = 4$  and the tangent to the ellipse at P passes through Q(4, 4) then PQ is equal to :
- (A)  $\frac{\sqrt{157}}{2}$  (B)  $\frac{5\sqrt{5}}{2}$   
(C)  $\frac{\sqrt{221}}{2}$  (D)  $\frac{\sqrt{61}}{2}$
79. Let  $\vec{a} = 3\hat{i} + 2\hat{j} + 2\hat{k}$  and  $\vec{b} = \hat{i} + 2\hat{j} - 2\hat{k}$  be two vectors. If a vector perpendicular to both the vectors  $\vec{a} + \vec{b}$  and  $\vec{a} - \vec{b}$  has the magnitude 12 then one such vector is:
- (A)  $4(2\hat{i} - 2\hat{j} - \hat{k})$  (B)  $4(2\hat{i} - 2\hat{j} + \hat{k})$   
(C)  $4(2\hat{i} + 2\hat{j} + \hat{k})$  (D)  $4(2\hat{i} + 2\hat{j} - \hat{k})$
80. The equation  $y = \sin x \sin(x + 2) - \sin^2(x + 1)$  represents a straight line lying in :
- (A) first, third and fourth quadrants (B) first, second and fourth quadrants  
(C) third and fourth quadrants only (D) second and third quadrants only

81. For  $x \in \left(0, \frac{3}{2}\right)$ , let  $f(x) = \sqrt{x}$ ,  $g(x) = \tan x$  and  $h(x) = \frac{1-x^2}{1+x^2}$ . If  $\phi(x) = ((h \circ f) \circ g)(x)$ , then  $\phi\left(\frac{\pi}{3}\right)$  is equal to :
- (A)  $\tan \frac{11\pi}{12}$  (B)  $\tan \frac{\pi}{12}$   
 (C)  $\tan \frac{5\pi}{12}$  (D)  $\tan \frac{7\pi}{12}$
82. If the angle of intersection at a point where the two circles with radii 5 cm and 12 cm intersect is  $90^\circ$ , then the length (in cm) of their common chord is :
- (A)  $\frac{13}{2}$  (B)  $\frac{120}{13}$   
 (C)  $\frac{13}{5}$  (D)  $\frac{60}{13}$
83. If  $\int_0^{\frac{\pi}{2}} \frac{\cot x}{\cot x + \operatorname{cosec} x} dx = m(\pi + n)$ , then  $m \cdot n$  is equal to
- (A) 1 (B)  $\frac{1}{2}$   
 (C)  $-\frac{1}{2}$  (D) -1
84. Let  $S_n$  denote the sum of the first  $n$  terms of an A.P.. If  $S_4 = 16$  and  $S_6 = -48$ , then  $S_{10}$  is equal to :
- (A) -410 (B) -260  
 (C) -320 (D) -380
85. If  $B = \begin{bmatrix} 5 & 2\alpha & 1 \\ 0 & 2 & 1 \\ \alpha & 3 & -1 \end{bmatrix}$  is the inverse of a  $3 \times 3$  matrix  $A$ , then the sum of all values of  $\alpha$  for which  $\det(A) + 1 = 0$ , is :
- (A) 0 (B) -1  
 (C) 1 (D) 2
86. If the line  $\frac{x-2}{3} = \frac{y+1}{2} = \frac{z-1}{1}$  intersects the plane  $2x + 3y - z + 13 = 0$  at a point  $P$  and the plane  $3x + y + 4z = 16$  at a point  $Q$ , then  $PQ$  is equal to :
- (A)  $2\sqrt{14}$  (B) 14  
 (C)  $2\sqrt{7}$  (D)  $\sqrt{14}$
87. If the volume of parallelepiped formed by the vectors  $\hat{i} + \lambda\hat{j} + \hat{k}$ ,  $\hat{j} + \lambda\hat{k}$  and  $\lambda\hat{i} + \hat{k}$  is minimum, then  $\lambda$  is equal to :
- (A)  $\sqrt{3}$  (B)  $\frac{1}{\sqrt{3}}$   
 (C)  $-\frac{1}{\sqrt{3}}$  (D)  $-\sqrt{3}$

88. If A is a symmetric matrix and B is a skew-symmetric matrix such that  $A + B = \begin{bmatrix} 2 & 3 \\ 5 & -1 \end{bmatrix}$ ,

then AB is equal to :

- (A)  $\begin{bmatrix} 4 & -2 \\ 1 & -4 \end{bmatrix}$  (B)  $\begin{bmatrix} 4 & -2 \\ -1 & -4 \end{bmatrix}$   
(C)  $\begin{bmatrix} -4 & 2 \\ 1 & 4 \end{bmatrix}$  (D)  $\begin{bmatrix} -4 & -2 \\ -1 & 4 \end{bmatrix}$

89. If the truth value of the statement  $p \rightarrow (\sim q \vee r)$  is false (F), then the truth values of the statement p, q, r are respectively :

- (A) T, T, F (B) F, T, T  
(C) T, F, T (D) T, F, F

90. For  $x \in \mathbb{R}$ , let  $[x]$  denote the greatest integer  $\leq x$ , then the sum of the series

- $\left[ -\frac{1}{3} \right] + \left[ -\frac{1}{3} - \frac{1}{100} \right] + \left[ -\frac{1}{3} - \frac{2}{100} \right] + \dots + \left[ -\frac{1}{3} - \frac{99}{100} \right]$   
(A) -135 (B) -153  
(C) -133 (D) -131

# JEE (Mains) – 2019

## ANSWERS

### PART A – PHYSICS

1.	C	2.	A	3.	B	4.	B
5.	D	6.	B	7.	A	8.	B
9.	B	10.	D	11.	C	12.	A
13.	A	14.	A	15.	B	16.	D
17.	C	18.	B	19.	A	20.	D
21.	D	22.	A	23.	B	24.	A
25.	D	26.	D	27.	D	28.	B
29.	C	30.	A				

### PART B – CHEMISTRY

31.	C	32.	C	33.	A	34.	D
35.	A	36.	C	37.	B	38.	C
39.	A	40.	B	41.	C	42.	B
43.	C	44.	C	45.	D	46.	D
47.	B	48.	A	49.	A	50.	A
51.	D	52.	A	53.	A	54.	D
55.	C	56.	C	57.	C	58.	C
59.	B	60.	B				

### PART C – MATHEMATICS

61.	C	62.	C	63.	B	64.	C
65.	A	66.	A	67.	B	68.	B
69.	D	70.	B	71.	B	72.	C
73.	A	74.	D	75.	C	76.	C
77.	D	78.	B	79.	A	80.	C
81.	A	82.	B	83.	D	84.	C
85.	C	86.	A	87.	Bonus	88.	B
89.	A	90.	C				